

Vue éclatée structure / Exploded view - Structure

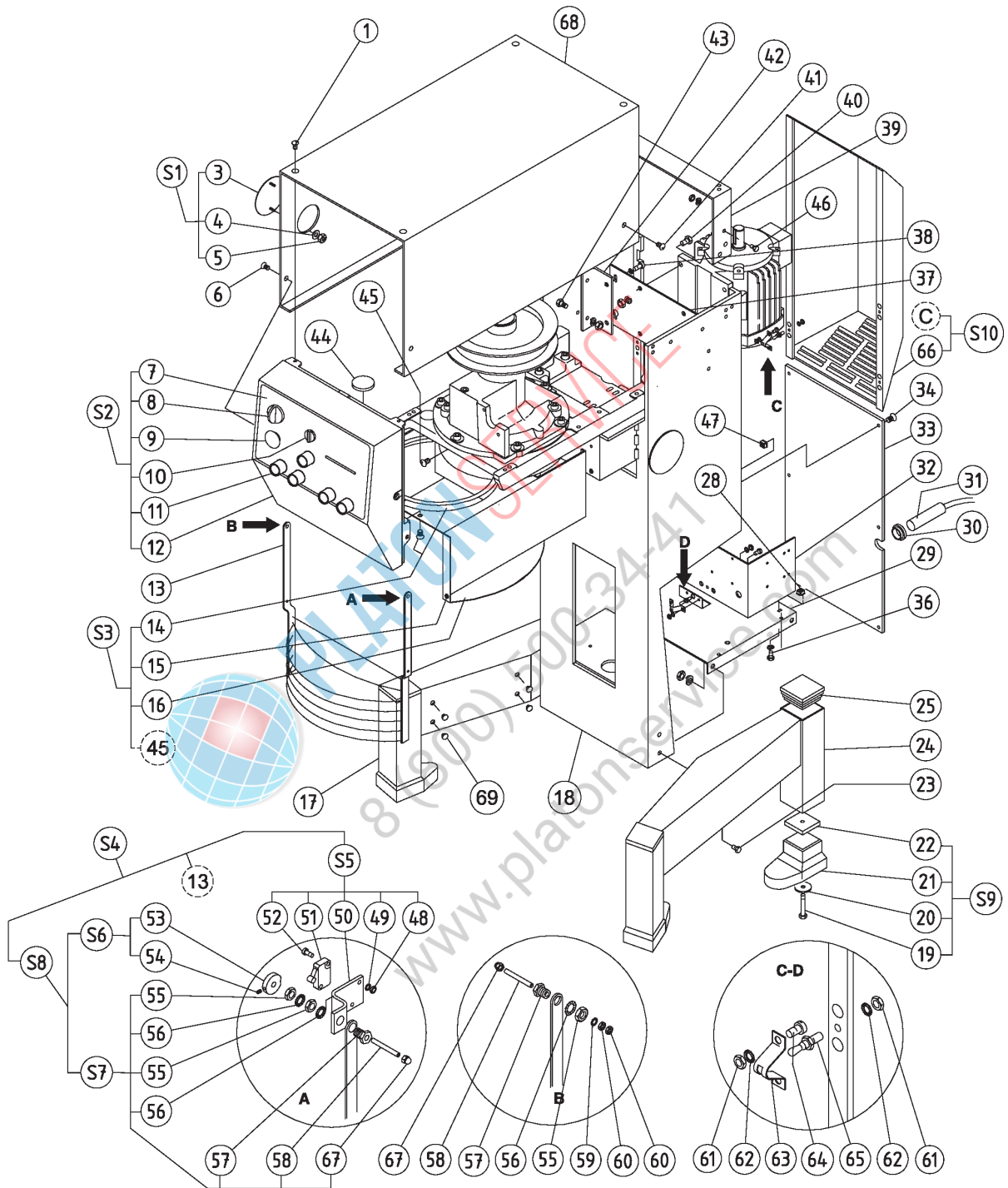

B

BMX60/80 FR 01 2013

Modell		601184							
Tafel		SPBMX(E)60-80		Seite		2		Explosionszeichnung - Rahmen	
Pos.	Ersatzteilnum	Alias Code	Ersetzt durch	S	Info	Kit	Techn. Mitteilung	Beschreibung	Bemerkungen
0001	0D0517				D			SCHRAUBE; 10 PCS	
0003	000000								See S1
0004	0D0631							SCHEIBE; SET 10PCS	
0005	OKL159							MUTTER; 10 PCS	
0006	0D0517				D			SCHRAUBE; 10 PCS	
0007	0D3286				D			CONTROL PANEL BMX60	
0007	0D5659				D			ARMATUREMBRETT; BMXE60	
0007	0D5660				D			ARMATUREMBRETT; BMXE80	
0007	0D5771				D			ARMATUREMBRETT; EM60	
0007	0D5772				D			ARMATUREMBRETT; EM80	
0008	OKQ287							ZEITSCHALTUHR	
0009	OKQ687							AUSSCHALTKNOPF;STOP-KNOPF	
0010	OKQ648							DREHGRIFF	
0011	OKJ038							STARTKNOPF	
0012	000000								See S2
0013	0D5216							GITTER; BMX60	
0014	0U0657							RUBBER STRIP	
0015	0D2706							SELF-ADHESIVE RUBBER STOP SET X10	
0016	000000								See S3
0017	0D2748				D			LEFT FOOT ASSY STLESS STL BMX60	
0017	0D3888				D			BEIGE LEFT FOOT ASSY BMX60/80	
0018	0D5663				D			STEIGROHR; BEIGE EQ BMX60	
0018	0D5664				D			STEIGROHR; INOX EQ BMX60	
0019	0D0598				D			SCHRAUBE; 10 PCS	
0020	0D3581							FOOT WASHER MV50 (SET X10)	
0021	000000								See S9
0022	0D1956							NUT BM30	
0023	0D2265				D			WASHER W10 BM40 SET X10	
0023	0D2958				D			NUT HU M10 GALVA STL (SET X10)	
0023	0D3554				D			SCREW H M10X25 AC 80 KG SET X10	
0024	0D1546				D			RH LEG ASSEMBLY	
0024	0D2747				D			RIGHT FOOT ASSY STLESS STL BMX60	
0025	OKQ432							STOEPSSEL; 10 STCK; BM30	
0028	0D1021				D			MUTTER; 10 PCS	
0029	0D5666				D			BLECHPLATTE; BMX60	
0030	0D6160				D			PASSEFIL DA 9X16X4 JEU X5	

Modell		601184							
Tafel		SPBMX(E)60-80		Seite		2		Explosionszeichnung - Rahmen	
Pos.	Ersatzteilnum	Alias Code	Ersetzt durch	S	Info	Kit	Techn. Mitteilung	Beschreibung	Bemerkungen
0031	0D1168				D			3/PHASE SUPPLY CABLE BM60	
0032	0D5667				D			HALTER; BMX60	
0033	0D3442				D			LOWER REAR PLATE STLESS STL BNX6	
0033	0D5668				D			TOLE ARRIERE; INF BEIGE BMX60	
0034	0D0601							SCHRAUBE; 10 PCS	
0036	0D0631							SCHEIBE; SET 10PCS	
0036	0D5298				D			SCHRAUBE; TH M4*12; T10-T15E; 10 PCS	
0037	0D5670				D			BLECHPLATTE; BMX60	
0038	0KQ492							SCHRAUBE	
0039	0D3889				D			OMEGA UPPER COLUMN BMX60	
0040	0D2265				D			WASHER W10 BM40 SET X10	
0040	0D2844				D			SCREW H M10X30 GALVA STL (SET X10)	
0040	0D2958				D			NUT HU M10 GALVA STL (SET X10)	
0041	0D0512							SCHRAUBE; 10 PCS	
0042	0D5671				D			HALTER; BMX60	
0043	0D5641							SCHRAUBE; CHC M10X30 ACZN (JEU X10)	
0044	0U0388							WINDOW	
0045	0D2901							SCREW H BASE 6X16 STLESS STL SET X10	
0046	0D2265				D			WASHER W10 BM40 SET X10	
0046	0D2958				D			NUT HU M10 GALVA STL (SET X10)	
0046	0D6064				D			VIS H M10X25 INOX (JEU X10)	
0047	0D5647				D			MUTTER; CAGE M6X3,6-4,5 (JX10)	
0048	033987							SCHRAUBE; 10 PCS	
0049	0D2877							WASHER GALVA STL3 SET X10	
0050	0D5672				D			HALTER	
0051	0D6661							MIKROSCHALTER; ECRAN BMX60/80	
0052	0KQ511							SCHRAUBE; 10 PCS	
0053	0U0391							NOCKEN	
0054	0KQ526							SCHRAUBE; 10 STCK.	
0055	0KQ554				D			MUTTER; 10 PCS	
0056	0KQ490				D			SCHEIBE; 10 PCS	
0057	0KQ333							BUCHSE	
0058	0D6761				D			SCHRAUBE; SHC M8X70 INOX (JEU X10)	
0059	0KQ523							MUTTER; 10 PCS	
0060	0KQ524							SCHEIBE; 10 PCS BMX60	
0061	0D0579				D			MUTTER; 10 PCS	

Modell		601184							
Tafel		SPBMX(E)60-80		Seite		2		Explosionszeichnung - Rahmen	
Pos.	Ersatz eilnum	Alias Code	Ersetzt durch	S	Info	Kit	Techn. Mitteilung	Beschreibung	Bemerkungen
0062	0KQ491							SCHEIBE; 10 PCS	
0063	0D5654				D			ATTACHE RAPID; (JEU X 5)	
0064	0D0614							SCREW TC 5X12	
0065	0D5444							SPANNSTIFT; BMX60 (JEU X5)	
0066	000000								See S10
0067	0KL161							MUTTER; 10 PCS	
0068	0D6476				D			DECKEL; M13 EQ BMX60/XBE60	
0068	0D6477				D			DECKEL; INOX EQ BMX/XBE	
0069	0D3601							PLUG GPN 300 F9 DIAM.60MM	
00S1	0D5655				D			ABDECKUNG; EQ BMX60/80	
00S2	0D0120				D			EQUIP. FRONT PANEL BMX60	
00S2	0D1857				D			FRONT PANEL ASSY BMXE60	
00S2	0D3287				D			FRONT PANEL ASSY BMXE80	
00S2	0KV687				D			FRONT PANEL ASSEMBLY	
00S3	0D6020				D			PROTECTION LATERALE EQ BMX60	
00S4	0D0195				D			BMX60/S WIRE SAFETY GUARD PC60	
00S5	0D1613							MIKROSCHALTER	
00S6	0D5656				D			NOCKEN; EQ BMX60/80	
00S7	0D5657				D			BUCHSE; ARTICULATION EQ BMX60/80	
00S8	0D1614							NOCKEN	
00S9	0KQ430							FUSS	
0S10	0D6478				D			HAUBE; ARRIERE SUP RAL1013 BMX6	
0S10	0D6479				D			HAUBE; ARRIERE SUP INOX EQ BMX6	

Vue éclatée variation vitesse mécanique/ Exploded view mechanical speed control

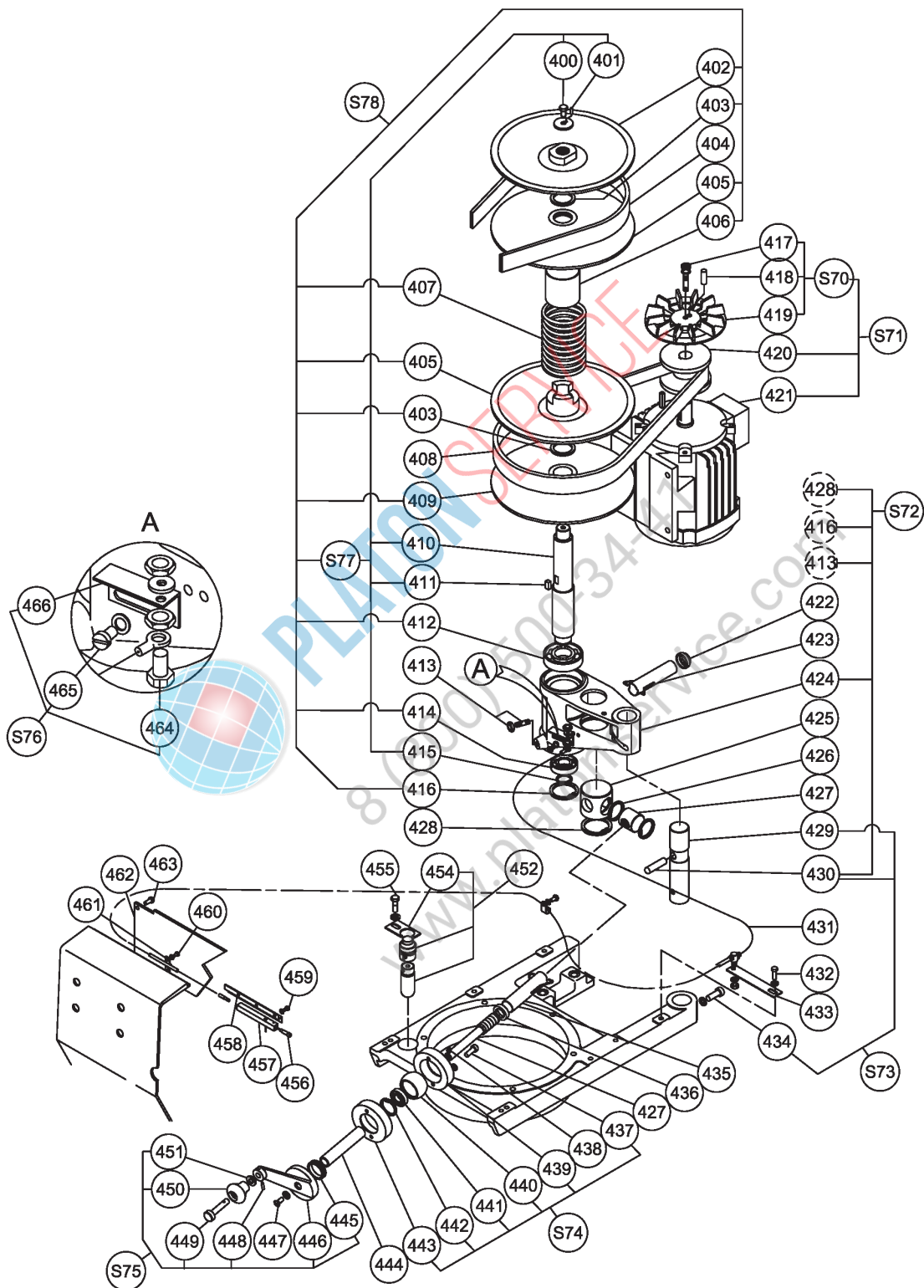

L

BMX60/80 FR 10 2010

Modell	601184										
Tafel	SPBMX(E)60-80		Seite	12		Explosionszeichnung - mechanische Geschwindigkeitsregelung					
Pos.	Ersatzteilnum	Alias Code	Ersetzt durch	S	Info	Kit	Techn. Mitteilung	Beschreibung	Bemerkungen		
0400	0D0507							SCHRAUBE; 10 STCK.			
0400	0D2323				D			FLANGE WASHER SET X10 BP45			
0401	0D3422							PIN GO5 4X10 STLESS STL SET X10			
0402	0D1310							RIEMENSCHLEIBE BM60			
0403	0KQ576							DICHTUNG;45X35X5 MM = 5 STUECK			
0404	0H1012							ANTRIEBSRIEMEN; W40X13X1365			
0405	0U0381							PULLEY FLANGE			
0406	0U0382							LAGERBUCHSE ZU BMX60			
0407	0D3848							SPRING BM80			
0407	0KQ343							FEDER			
0408	0KJ740							TRIEBRIEMEN; W40X13X875			
0409	0D1311							BM60 FIXED LOWER FLANGE			
0410	000000								See S77		
0411	0D5728							KEIL; 10X8X20 H9 (JX10)			
0412	0D1124							BM60 BEARING 6207 2RS			
0413	0D0642							MUTTER; 10 STCK.			
0413	0D1663				D			SCHRAUBE; 10 PCS			
0414	0D0006							LAGER; 6206 2RS			
0415	0D0654							B40/BM40/BM60/BE21 CIRCLIP 30E			
0416	0U0717							SCHLAUCHBAND; 10 PCS			
0417	0D1663				D			SCHRAUBE; 10 PCS			
0417	0D3538							WASHER CS L8 GALVA STL8B (SET X10)			
0418	0KJ021							SPLINT; 5 PCS			
0419	000000								See S70		
0420	0D1312				D			BM60 DRIVE PULLEY			
0420	0D5342							ANTRIEBSSCHLEIBE; DEAN EQ BMX60			
0421	000000								See S71		
0421	0D1599							MOTOR; 440V 3PH 3,7A 2KW			
0421	0KQ289							MOTOR			
0422	0D0529							STOEPSSEL; 10 PCS			
0423	0U0401				D			SCHRAUBE			
0424	000000								See S72		
0425	0D0322							UNIVERSAL JOINT BMX80			
0426	0U0618							CIRCLIP 35I			
0427	0D1834				D			MANUAL CONTROL SCREW NUT BMX60			
0428	0D0578							SCHLAUCHBAND; 10 PCS			

Pos.	Ersatzteilnum	Alias Code	Ersetzt durch	S	Info	Kit	Techn. Mitteilung	Beschreibung	Bemerkungen
Modell	601184								
Tafel	SPBMX(E)60-80		Seite	12		Explosionszeichnung - mechanische Geschwindigkeitsregelung			
0429	000000								See S73
0430	0D0666							STIFT; 5 PCS	
0431	0D0121							BMX60/80 SPEEDOMETER CABLE	
0432	0D0632							UNTERLEGSCHLEIBE CS M8; 10 STCK.	
0432	0D1709							SCHRAUBE; 10 PCS	
0433	0D5731				D			PATTE SUPPORT GAINE; BM60	
0434	0D2265				D			WASHER W10 BM40 SET X10	
0434	0D5641							SCHRAUBE; CHC M10X30 ACZN (JEU X10)	
0435	0D5733				D			FORREAU PROTECTION; AV BM60	
0436	0KQ307							SLEEVE BUSH	
0437	0D0599							SCHRAUBE; 10 PCS	
0437	0D0619							SHEIBE; 10 PCS	
0438	0D0552							5 PCS KEY 4X4X16	
0439	000000								See S74
0440	000000								See S74
0441	0D2393							BEARING 3202B-2RS	
0442	0U0618							CIRCLIP 35I	
0443	000000								See S74
0444	0D3890							ENTRETOISE 15,8X21,3X111 BMX60	
0445	0D1134				D			V-RING 30X4X7,5	
0446	000000								See S75
0447	0D0020							SCHEIBE	
0447	0D0664							SCHRAUBE; 10 PCS	
0448	0D0671							STIFT; 10 PCS	
0449	000000								See S75
0450	000000								See S75
0451	0D1219							WASHER 10X20X1	
0452	0KQ375							LEUCHTSTOFFLAMPE; 220V 40W;26X80; NEU	
0454	0D1557				D			WINKEL; BUCHSE	
0455	0D0507							SCHRAUBE; 10 STCK.	
0455	0D0626							SHEIBE; 10 PCS	
0456	0KQ447							KONTROLLAMPE; 220V	
0457	0KL039							HALTER	
0458	0KQ624				D			GLEITSCHIENE	
0459	0D0609							SCHRAUBE; 10 PCS	
0459	0D0621				D			SHEIBE; 10 PCS	

Modell 601184

Tafel SPBMX(E)60-80 Seite 12 Explosionszeichnung - mechanische Geschwindigkeitsregelung

Pos.	Ersatzteilnum	Alias Code	Ersetzt durch	S	Info	Kit	Techn. Mitteilung	Beschreibung	Bemerkungen
0460	0D0610							K35 SCREW TC 4X8	
0460	0D0631							SCHEIBE; SET 10PCS	
0461	0D5735				D			PATTE BLOCAGE CABLE BM60 (JX5)	
0462	0D5736							TOLE PROTECTION; BMX60	
0463	0D5276							SCHRAUBE; TC M6*10 T10-15E; 10 PCS	
0464	0D0579				D			MUTTER; 10 PCS	
0464	0D5737				D			MUTTER; HM M5 INOX (JEU X10)	
0464	0KQ407							SCHRAUBE; 10 STCK.	
0464	0KQ491							SCHEIBE; 10 PCS	
0465	0D0549							SCHRAUBE; 10 PCS	
0465	0D0619							SHEIBE; 10 PCS	
0466	000000								See S76
0S70	0D5730				D			LUEFTERMOTOR; EQ BMX60/80	
0S70	0U0384				D			LUEFTERRAD; MODEL EM60/80 MIXER	
0S71	0D2509				D			MOTOR 1 208/240 60 ASSY EM60/80	
0S71	0D2510				D			MOTOR 3 208/240 60 ASSY EM60/80	
0S72	0D0193							HINGE	
0S73	0U0244				D			HINGE PIN	
0S74	0U0257							LAGER	
0S75	0KJ746							KNEBEL	
0S76	0D0198				D			BM60 EQUIP. CABLE STOP	
0S77	0D0182							BM60 VARIABLE PULLEY SHAFT	
0S78	0D0065							BMX60 SHAFT+VARIABLE PULLEYS	

Vue éclatée monte et baisse bol / Exploded view - Raising and lowering of bowl

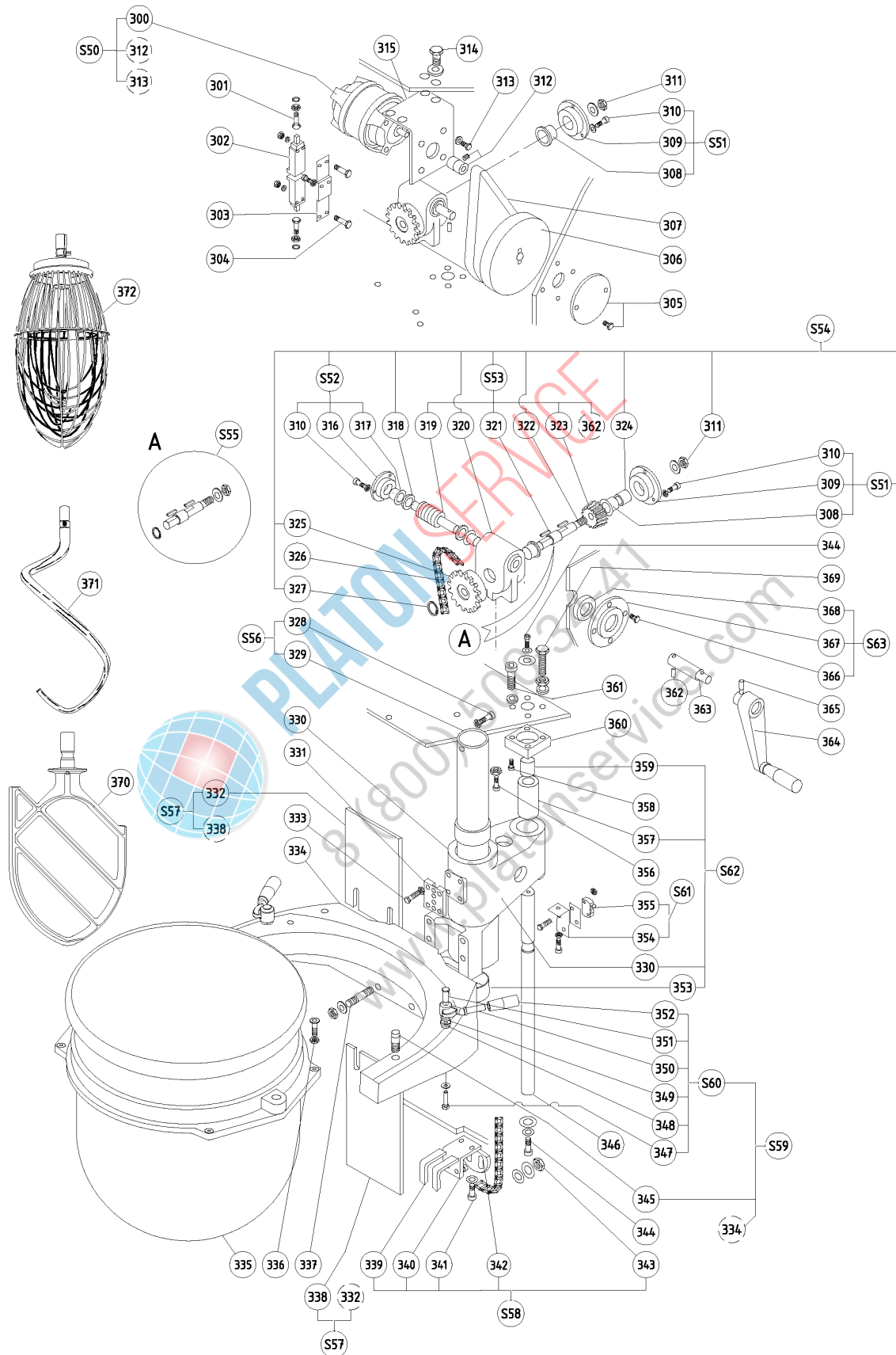

V

BMX60/80 FR 07 06

Pos.	Ersatzteilnum	Alias Code	Ersetzt durch	S	Info	Kit	Techn. Mitteilung	Beschreibung	Bemerkungen
Modell	601184								
Tafel	SPBMX(E)60-80		Seite	22		Explosionszeichnung - Hebe- und Senkvorrichtung			
0300	000000								See S50
0301	0D0598				D			SCHRAUBE; 10 PCS	
0302	0KQ206							SCHALTER	
0303	0D3891				D			MICRO LIFT/LOWER SUPPORT BMX60	
0304	0D0520							STIFT; 10 PCS	
0304	0D3399							SCREW CHC M4X40 STLESS STL SET X10	
0304	0KL159							MUTTER; 10 PCS	
0305	0D5309							ABDECKUNG; EQ BMX60	
0306	0D1559				D			BMX60 RAISING LOWERING PULLEY	
0307	033106							KEILRIEMEN	
0308	0D5708				D			LAGER; COL 20X26X20 FP25 US	
0309	000000								See S51
0310	0D0617							ZYLINDERSCHRAUBE M6X16 AC80;	
0310	0D2876							WASHER W6 SET X10	
0311	0D0622							SHEIBE; 10 PCS	
0311	0D2958				D			NUT HU M10 GALVA STL (SET X10)	
0312	0D0545							SCHRAUBE; 10 PCS	
0312	0D1558							POULIE MOTRICE M/B BMX60	
0313	0D0624			S				SCHEIBE; SET 10 STCK.;	
0313	0KQ494							SCHRAUBE; 10 STCK.	
0314	0D2329				D			SCREW H M8X30 SET X10	
0314	0D3538							WASHER CS L8 GALVA STL8B (SET X10)	
0315	0D3892				D			SUPPORT MOTOR BMX60	
0316	000000								See S52
0317	0D6031				D			KUGELLAGER; 15X51X20	
0318	0D5710				D			SCHEIBE; 30X15X2 (JX2)	
0319	000000								See S53
0320	0D5711							BOITIER REDUCTEUR; DEG BMX60	
0321	0HD008							KEIL; 5 STCK.	
0322	000000								See S55
0323	000000								See S53
0324	0D5712				D			DISTANZSTUECK; BM60	
0325	0KQ341							CHAIN GEER WHEEL	
0326	0KQ607							CHAIN + QUICK RELEASE	
0327	0KQ557							RING; 10 PCS	
0328	0D0499							SCHRAUBE; 10 PCS	

Modell	601184								
Tafel	SPBMX(E)60-80		Seite	22		Explosionszeichnung - Hebe- und Senkvorrichtung			
Pos.	Ersatzteilnum	Alias Code	Ersetzt durch	S	Info	Kit	Techn. Mitteilung	Beschreibung	Bemerkungen
0328	0D0503							MUTTER; 10 STCK.	
0329	000000								See S56
0330	000000								See S61
0331	0D5714				D			BRIDE CHAINE PEINT; BMX60	
0332	000000								See S57
0333	0D6084				D			VIS H EMB CRANTEE M8X30 (JX10)	
0334	000000								See S59
0335	653087							ZUSATZKESSEL 60L	
0335	653132							KESSEL FÜR 80L RÜHRMASCH.	
0336	0D0020							SCHEIBE	
0336	0D1031							SCHRAUBE; 10 PCS	
0337	0D5700				D			SCHEIBE; W 12 (JEU X5)	
0337	0D5716				D			GOUJON; M12X68X25X25 ACDXZN JX6	
0337	0KQ496							SCHEIBE; 10 PCS	
0338	000000								See S57
0339	0D2702							SEAL STRIP 7X4 W:0.5 TBX130	
0340	000000								See S58
0341	0D2265				D			WASHER W10 BM40 SET X10	
0341	0U0662							SCHRAUBE; 10 PCS	
0342	0D5715				D			PATIN DE TENDEUR; BM60	
0343	0D2958				D			NUT HU M10 GALVA STL (SET X10)	
0343	0D3580				D			TOOTHED WASHER DD10 GALVA STL8B SET X10	
0343	0KQ506							SCHEIBE; 10 PCS	
0344	0D0499							SCHRAUBE; 10 PCS	
0344	0D3576							MILLED WASHER (SET X5)	
0345	0D1030							STIFT; 2 PCS	
0346	0D3637							LIFT LOWER ROD BM60	
0347	0D0591							SCHRAUBE; 10 STCK.	
0347	0D3538							WASHER CS L8 GALVA STL8B (SET X10)	
0348	0D5717				D			DISTANZSTUECK; (JX2)	
0349	0D2662							O-RING 15.54X2.62 EL25 X5	
0350	000000								See S60
0351	0D6109				D			AXE VERROU XB40 (JEU X2)	
0352	0D6125				D			POIGNEE I580/65 N-12	
0353	0U0399							BUCHSE	
0354	000000								See S61

Pos.	Ersatzteilnum	Alias Code	Ersetzt durch	S	Info	Kit	Techn. Mitteilung	Beschreibung	Bemerkungen
Modell	601184								
Tafel	SPBMX(E)60-80		Seite	22		Explosionszeichnung - Hebe- und Senkvorrichtung			
0354	0D0631							SCHEIBE; SET 10PCS	
0354	0D5298				D			SCHRAUBE; TH M4*12; T10-T15E; 10 PCS	
0355	033986							SCHRAUBE; 10 PCS	
0355	033987							SCHRAUBE; 10 PCS	
0355	0D2877							WASHER GALVA STL3 SET X10	
0355	0D6618							MIKROSCHALTER; MONTE/BAISSE 60L	
0355	0KQ511							SCHRAUBE; 10 PCS	
0355	0U0268							ISOLIERPLATTE	
0356	0D2958				D			NUT HU M10 GALVA STL (SET X10)	
0356	0D6064				D			VIS H M10X25 INOX (JEU X10)	
0357	000000								See S62
0358	0D5718				D			SCHRAUBE; FHC M10X20 AC 80 (JX10)	
0359	0D5719				D			LAGER; 24X27X20 PA	
0360	0D4743								
0361	0D2265				D			WASHER W10 BM40 SET X10	
0361	0D5641							SCHRAUBE; CHC M10X30 ACZN (JEU X10)	
0362	0D0396							STIFT; SET 10 STCK.	
0363	0U0389				D			WELLE	
0364	0D3959							GRIFF; ASSY	
0365	0D6180							GOUPILLE G01 5X30 (JEU X10)	
0366	0D0664							SCHRAUBE; 10 PCS	
0367	000000								See S63
0368	0D3636				D			HANDLE RING BM60	
0369	0D5722				D			SCHRAUBE; H M10X55 INOX (JEU X10)	
0370	653083							ZUSATZFLACHRÜHRER 60L	
0370	653135							SCHLÄGER FÜR 80L RÜHRMASCH.	
0370	653457							FLEISCHKNETHAKEN 60L	
0371	653084							ZUSATZKNETHAKEN 60L	
0371	653133							TEIGKNETER FÜR 80L RÜHRMASCH.	
0371	653481							EXTRA SCHWERER HAKEN 60 L PLANETNEMIX.	
0372	653086							ZUSATZBESEN 60L	
0372	653134							BESEN FÜR 80L RÜHRMASCH.	
0372	653458							FLEISCHBESEN 60L	
0S50	0KQ668							MOTOR	
0S51	0D5723				D			DRUCKKUGELLAGER; EQ BMX60	
0S52	0D5709				D			DRUCKKUGELLAGER; EQ BMX60	

Modell 601184

Tafel SPBMX(E)60-80 Seite 22 Explosionszeichnung - Hebe- und Senkvorrichtung

Pos.	Ersatzteilnum	Alias Code	Ersetzt durch	S	Info	Kit	Techn. Mitteilung	Beschreibung	Bemerkungen
0S53	0U0540							GEAR	
0S54	0U0248							GETRIEBEGEHAEUSE KPL. BMXE	
0S55	0U0247							REDUCTION SHAFT FOR BOWL LIFT	
0S56	0D5310							SCHLAUCH; D60 EQ BM60	
0S57	0D5811				D			TOLE PROTECTION INF/SUP BMX60	
0S58	0U0249				D			TENSIONING BLOCK & BRACKET	
0S59	0D5725								
0S59	0U0250				D			BOWL SUPPORT EM80	
0S60	0D6117							RIEGELSTUECK; XBM40	
0S61	0D5724							MIKROSCHALTER; M/B EQ BMX60	
0S62	0D5713				D			HALTER; EQ BMX60	
0S63	0D5721				D			DRUCKKUGELLAGER; EQ BMX60	



PLATON SERVICE
8 (800) 500-34-47
www.platonservice.com

Vue éclatée variateur / Exploded view - head with accessory socket

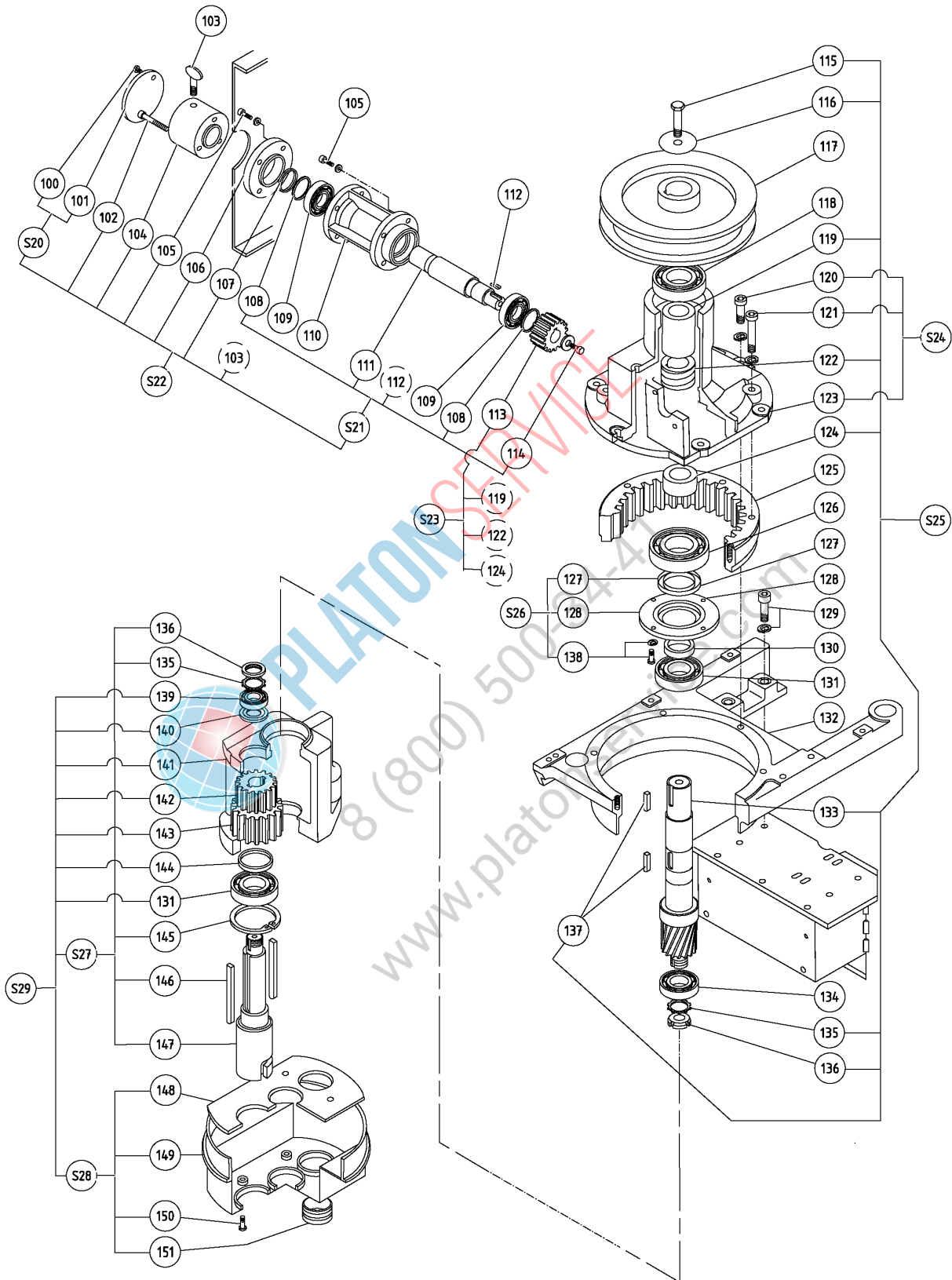

FF

BMX60/80 FR 06 06

Modell	601184								
Tafel	SPBMX(E)60-80	Seite	32	Explosionszeichnung - Kopf mit Aufstecknabe					
Pos.	Ersatzteilnum	Alias Code	Ersetzt durch	S	Info	Kit	Techn. Mitteilung	Beschreibung	Bemerkungen
0100	0D3547				D			SCREW F M4X12 STLESS STL (SET X10)	
0101	000000								See S20
0102	0D1018							SCHRAUBE; 10 PCS	
0103	0KQ334							SCHRAUBE; M10X30	
0104	0KL098							SHEATH	
0105	0D0657							SCHRAUBE; 10 PCS	
0105	0D2876							WASHER W6 SET X10	
0106	0D5692				D			DISTANZSTUECK; PA BM60	
0107	0H1040							DICHTUNG; 30X40X7 BM20; 5 STCK.	
0108	0D0654							B40/BM40/BM60/BE21 CIRCLIP 30E	
0109	0KT993							ROLLLAGER 6006 2RS	
0110	0D5693				D			PORTE CANON; DEG BMX60	
0111	000000								See S21
0112	0D0637							SCHLUESSEL; 5 PCS	
0113	0D1226				D			BM60 ATTACHMENT HUB WHEEL	
0114	0D3576							MILLED WASHER (SET X5)	
0114	0KQ520							SCHRAUBE; 10 STCK.	
0115	0D3554				D			SCREW H M10X25 AC 80 KG SET X10	
0116	0D5695							SCHEIBE; POULIE 60X10 (JEU X5)	
0117	0D5706				D			RIEMENSCHLEIBE; BMX60	
0118	0D1129							BM60 6308EE BEARING	
0119	0D5780								
0120	0D2265				D			WASHER W10 BM40 SET X10	
0120	0D6099							VIS CHC M10X40 AC 80 (JEU X10)	
0121	0D2265				D			WASHER W10 BM40 SET X10	
0121	0D5696							SCHRAUBE; CHC M10X60 AC.80KG (J X10)	
0122	0D1726				D			SCHRAUBE	
0123	000000								See S24
0124	0D5781								
0125	0D3168							CROWN GEAR 53TEETH ASSY BMX60	
0126	0D1130							BEARING; 6309 2RS	
0127	0D1133				D			BM60 C 55 X 70 X 8 SEAL	
0128	000000								See S26
0129	0D5699				D			SCHRAUBE; CHC M12X45 AC.80KG (J X5)	
0129	0D5700				D			SCHEIBE; W 12 (JEU X5)	
0130	0U0374							SUN GEAR SHAFT SPACER	

Modell		601184									
Tafel		SPBMX(E)60-80		Seite		32		Explosionszeichnung - Kopf mit Aufstecknabe			
Pos.	Ersatzteilnum	Alias Code	Ersetzt durch	S	Info	Kit	Techn. Mitteilung	Beschreibung	Bemerkungen		
0131	0HD044							BEARING; TR-300			
0132	0D5701				D			PLATINE EMBALLEE; BMX60			
0133	000000								See S25		
0134	0KJ748							KUGELLAGER			
0135	0D5042							SCHEIBE; MB5			
0136	0D0002							MUTTER			
0137	0D0543							SCHEIBE; 5 PCS			
0138	0D0499							SCHRAUBE; 10 PCS			
0138	0D0624			S				SCHEIBE; SET 10 STCK.;			
0139	0KQ394							LAGER 6205 2RS			
0140	0U0375							UPPER SPACER			
0141	0D1216							PLANETARY HOUSING BMX60			
0142	0U0373							RITZEL; 17 ZAEHNE; EMX60			
0143	0U0372							RITZEL; 24 ZAEHNE; BM60			
0144	0U0376							LOWER SPACER (EMX80)			
0145	0U0668							SCHLAUCHBAND; 5 PCS			
0146	0D2340							KEIL A10X8X115 ; 2-ER SATZ			
0147	000000								See S27		
0148	0U0292							DICHTUNG			
0149	000000								See S28		
0150	0D0595							SCHRAUBE; 10 STCK.			
0151	0D1054				D			STOEPSSEL; 4 PCS			
0S20	0KL100							COVER PLATE ASSEMBLY			
0S21	0D2545							ACCSSRY SOCKT SHAFT ASSY BMX60			
0S22	0D0958				D			BMX60/80 ATTACHMENT HUB ASSY			
0S23	0U0540							GEAR			
0S24	0D5703				D			DRUCKKUGELLAGER; PA EQ BMX60			
0S25	0D1409							WELLE SONNENRAD;MIT SCHRAUBE;BM60/80			
0S26	0U0698							BEARING COVER & SEAL			
0S27	0U0243							WERKZEUGHALTERWELLE AUSGESTATTET;BM60			
0S28	0D5204							GEHAEUSE; BM60			
0S28	0D5704										
0S29	0D1858				D			PLANETARY SUPPORT ASSY BMX60/80			
0S29	0D5705				D			HALTER; STD EQ BMX6			

Vue éclatée tête sans prise accessoires / Exploded view - head without accessory socket / Explosionszeichnung Kopf ohne Aufstecknabe

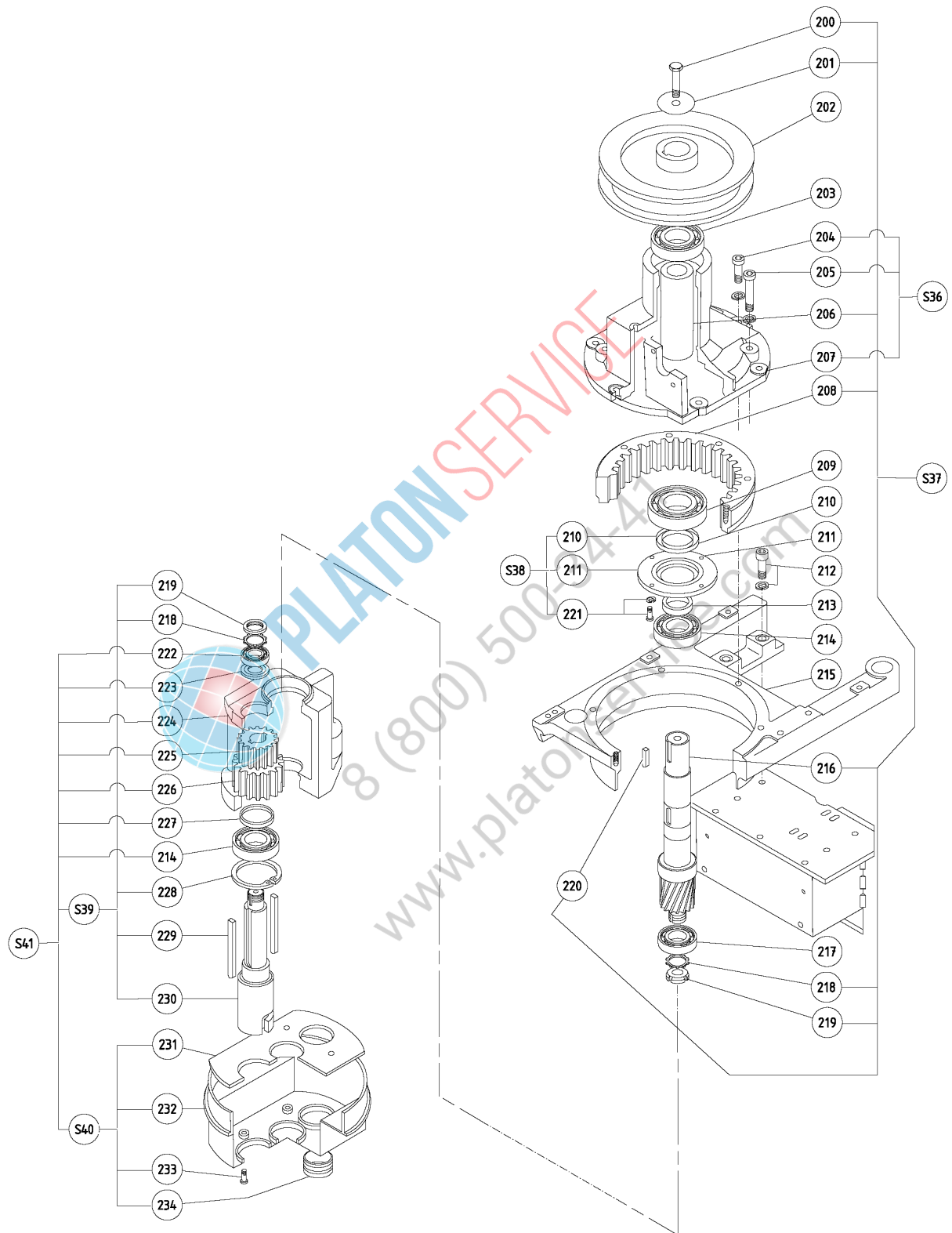

PP

BMX60/80 FR 06 06

Pos.	Ersatzteilnum	Alias Code	Ersetzt durch	S	Info	Kit	Techn. Mitteilung	Beschreibung	Bemerkungen
Modell	601184								
Tafel	SPBMX(E)60-80		Seite	42		Explosionszeichnung Kopf ohne Aufstecknabe			
0200	0D3554				D			SCREW H M10X25 AC 80 KG SET X10	
0201	0D5695							SCHEIBE; POULIE 60X10 (JEU X5)	
0202	0D5706				D			RIEMENSCHLEIBE; BMX60	
0203	0D1129							BM60 6308EE BEARING	
0204	0D2265				D			WASHER W10 BM40 SET X10	
0204	0D6099							VIS CHC M10X40 AC 80 (JEU X10)	
0205	0D2265				D			WASHER W10 BM40 SET X10	
0205	0D5696							SCHRAUBE; CHC M10X60 AC.80KG (J X10)	
0206	0D5732								
0207	000000								See S36
0208	0D3168							CROWN GEAR 53TEETH ASSY BMX60	
0209	0D1130							BEARING; 6309 2RS	
0210	0D1133				D			BM60 C 55 X 70 X 8 SEAL	
0211	000000								See S38
0212	0D5699				D			SCHRAUBE; CHC M12X45 AC.80KG (J X5)	
0212	0D5700				D			SCHEIBE; W 12 (JEU X5)	
0213	0U0374							SUN GEAR SHAFT SPACER	
0214	0HD044							BEARING; TR-300	
0215	0D5701				D			PLATINE EMBALLEE; BMX60	
0216	000000								See S37
0217	0KJ748							KUGELLAGER	
0218	0D5042							SCHEIBE; MB5	
0219	0D0002							MUTTER	
0220	0D0543							SCHEIBE; 5 PCS	
0221	0D0499							SCHRAUBE; 10 PCS	
0221	0D0624			S				SCHEIBE; SET 10 STCK.;	
0222	0KQ394							LAGER 6205 2RS	
0223	0U0375							UPPER SPACER	
0224	0D1216							PLANETARY HOUSING BMX60	
0225	0U0373							RITZEL; 17 ZAEHNE; EMX60	
0226	0U0372							RITZEL; 24 ZAEHNE; BM60	
0227	0U0376							LOWER SPACER (EMX80)	
0228	0U0668							SCHLAUCHBAND; 5 PCS	
0229	0D2340							KEIL A10X8X115 ; 2-ER SATZ	
0230	000000								See S39
0231	0U0292							DICHTUNG	

Modell 601184

Tafel SPBMX(E)60-80 Seite 42 Explosionszeichnung Kopf ohne Aufstecknabe

Pos.	Ersatzteilnum	Alias Code	Ersetzt durch	S	Info	Kit	Techn. Mitteilung	Beschreibung	Bemerkungen
0232	000000								See S40
0233	0D0595							SCHRAUBE; 10 STCK.	
0234	0D1054				D			STOEPSEL; 4 PCS	
0S36	0D2713				D			REDUCER BEARING W/O ACCSSRY SOCKT ASSY B	
0S37	0KL002							SUN SHAFT ASSEMBL; EMX60/80	
0S38	0U0698							BEARING COVER & SEAL	
0S39	0U0243							WERKZEUGHALTERWELLE AUSGESTATTET;BM60	
0S40	0D5204							GEHAEUSE; BM60	
0S40	0D5704								
0S41	0D1858				D			PLANETARY SUPPORT ASSY BMX60/80	
0S41	0D5705				D			HALTER; STD EQ BMX6	



PLATON SERVICE
8 (800) 500-34-41
www.platonservice.com

**Vue éclatée variation vitesse électrique / Exploded view
 electric speed control / Explosionszeichnungelektronische
 Geschwindigkeitsregelung**

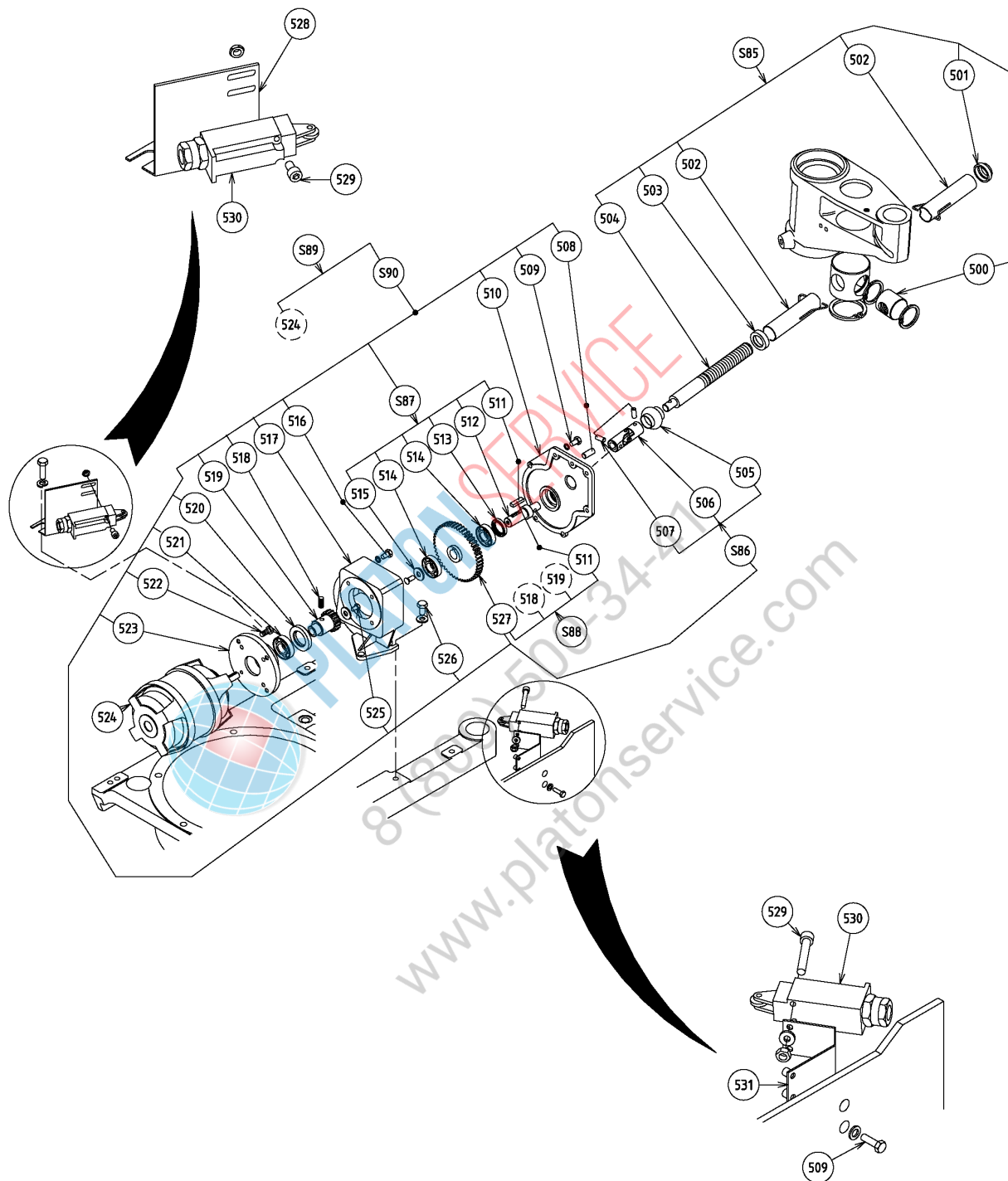

Modell		601184									
Tafel		SPBMX(E)60-80		Seite		48		Explosionszeichnungs		elektronische Geschwindigkeitsregelung	
Pos.	Ersatzteilnum	Alias Code	Ersetzt durch	S	Info	Kit	Techn. Mitteilung	Beschreibung	Bemerkungen		
0500	OKQ539							MUTTER			
0501	0D0529							STOEPSEL; 10 PCS			
0502	0U0401				D			SCHRAUBE			
0503	OKQ307							SLEEVE BUSH			
0504	0D5740				D			SCHRAUBE; USINNE BMX60/80			
0505	0G1694							HALTER			
0506	0G1693							GELENK			
0507	0U0663							STIFT; 10 PCS			
0508	OKQ500							STIFT; 10 PCS			
0509	0D0499							SCHRAUBE; 10 PCS			
0509	0D0624			S				SCHEIBE; SET 10 STCK.;			
0510	0D5753				D			DECKEL; DEG BMX60			
0511	0D0646				D			B20 KEY REP 66B			
0512	000000								See S87		
0513	OKI591							DICHTUNGSRING			
0514	0U0582							LAGER			
0515	0D0020							SCHEIBE			
0515	OKQ520							SCHRAUBE; 10 STCK.			
0516	OKQ407							SCHRAUBE; 10 STCK.			
0516	OKQ514				D			DICHTUNG; SET 10 STCK.			
0517	0D3466				D			CASING ONLY SPEED REDUCER BMXE60			
0518	0D0545							SCHRAUBE; 10 PCS			
0519	000000								See S88		
0520	OKQ579							SEAL 24X40X7, INOUT SHAFT; 5 PCS			
0521	0U0282				D			LAGER			
0522	0D5276							SCHRAUBE; TC M6*10 T10-15E; 10 PCS			
0523	0D5741				D			ADAPTER; MOTEUR BM60			
0524	0D5742				D			MOT 3 220/380 60 CGHT V BMX60			
0524	0U0541							MOTOR			
0525	0D0545							SCHRAUBE; 10 PCS			
0525	0D5743				D			SCHEIBE; 4,5X14X2 (JEU X10)			
0526	0D0632							UNTERLEGSCHIEBE CS M8; 10 STCK.			
0526	0D0642							MUTTER; 10 STCK.			
0526	0D5444							SPANNSTIFT; BMX60 (JEU X5)			
0527	000000								See S88		
0528	0D5744							HALTER; BMX60			

Pos.	Ersatz eilnum	Alias Code	Ersetzt durch	S	Info	Kit	Techn. Mitteilung	Beschreibung	Bemerkungen
0529	0D0520							STIFT; 10 PCS	
0529	0D3399							SCREW CHC M4X40 STLESS STL SET X10	
0529	0KL159							MUTTER; 10 PCS	
0530	0KQ206							SCHALTER	
0531	0U0485				D			MINI MICRO SPEED BRACKET	
0S85	0G1692							WELLE	
0S86	0KQ667							PLANETARY GEAR ASSY.	
0S87	0D2712				D			OUTPUT SHAFT ASSY BMXE60/80	
0S88	0D3465							SPEED REDUCER PINION BMXE60/80 (SET)	
0S89	0U0585							MOTOR	
0S90	0D6613				D			GETRIEBE; ELECT.BMXE60	



PLATON SERVICE
 8 (800) 500-34-41
www.platonservice.com